



## Table of Contents

|      |   |    |
|------|---|----|
| 1    | Identification: .....   | 2  |
| 1.1  | General .....   | 2  |
| 1.2  | Product Label and Type Designation. ....                              | 2  |
| 1.3  | Product version/Electric version.....                                 | 2  |
| 1.4  | Declaration of Conformity.....  | 3  |
| 1.5  | Applied standards .....   | 4  |
| 2    | Product Description: .....  | 5  |
| 2.1  | Product Supply and Consumption Data.....                              | 5  |
| 2.2  | Keeping.....  | 6  |
| 2.3  | Safety Information .....  | 6  |
| 3    | Definitions: .....  | 7  |
| 4    | Preparation of product prior to use: .....                            | 8  |
| 4.1  | Transport.....  | 8  |
| 4.2  | Unwrapping. ....  | 8  |
| 4.3  | Dismantling from transport pallet.....                                | 9  |
| 4.4  | Setting Up.....   | 10 |
| 4.5  | Mounting in floor .....   | 11 |
| 4.6  | Safety Measures prior to use. ....                                    | 11 |
| 4.7  | Disposal of Wrapping.....   | 11 |
| 4.8  | Protection in periods without normal use. ....                        | 11 |
| 4.9  | Rewrapping.....   | 11 |
| 4.10 | Placing of guide.....   | 11 |
| 5    | Operation. ....   | 12 |
| 5.1  | Stacking Function Description. ....                                   | 13 |
| 5.2  | De-stacking Function Description.....                                 | 13 |
| 5.3  | Function description for removal of pallet stack. ....                | 14 |
| 5.4  | Activation of Front Sensor .....                                      | 14 |
| 5.5  | Activation of Emergency Stop / Hatch switch. ....                     | 14 |
| 5.6  | Description of the light tower (Option). ....                         | 14 |
| 6    | Maintenance and Cleaning.....   | 14 |
| 6.1  | Safety Measures.....  | 14 |
| 6.2  | Maintenance and Cleaning. ....  | 15 |
| 6.3  | Service Form. ....  | 15 |
| 7    | Troubleshooting.....  | 15 |
| 7.1  | Troubleshooting Procedure.....  | 17 |
| 7.2  | Error Codes.....  | 18 |
| 7.3  | Troubleshooting actuators. ....                                       | 18 |
| 7.4  | Trouble shooting step by step on PLC.....                             | 19 |
| 8    | List of Spare Parts and Consumables.....                              | 21 |
| 8.1  | Spare Parts Drawing .....   | 21 |
| 8.2  | Wiring Diagram.....   | 22 |
| 9    | Taking product out of service. ....                                   | 23 |
| 9.1  | Own Notes:.....   | 23 |
| 10   | Options.....  | 24 |
| 10.1 | Assembly Guide for subsequent assembly of 15-pallet safety frame..... | 24 |
| 10.2 | Assembly Guide for subsequent assembly of 25-pallet safety frame..... | 25 |
| 10.3 | Installation instructions for 25 pallets Max indicator (Option). .... | 26 |
| 10.4 | Adjustment of the Max indicator .....                                 | 26 |
| 11   | Appendix.....   | 27 |
| 11.1 | Linak management TR-EM-239 Parallel Drive .....                       | 27 |

# 1 Identification:

## 1.1 General

This instruction manual is the English translated version of the original Danish instruction manual. It is supplied with the Palomat.

The purpose of this instruction manual is to ensure proper handling, installation, operation and maintenance of the Palomat.

The instruction manual should be kept in a place known to the staff for easy access by the operators and maintenance personnel.

## 1.2 Product Label and Type Designation.

This manual applies to all Palomats of type Palomat Greenline.

## 1.3 Product version/Electric version

See documentation front page and the type label on the side of the machine.

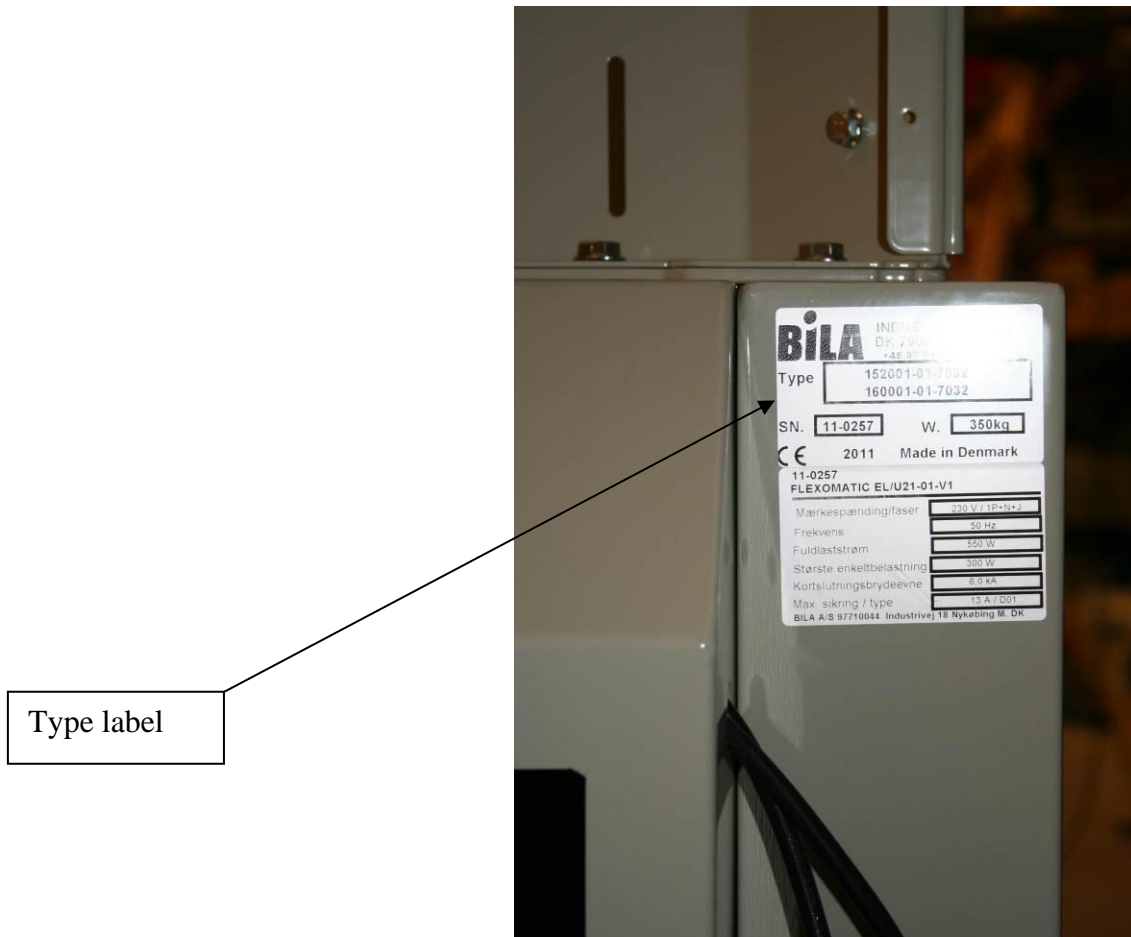

## Manufacturer/Distributor.

See documentation front page.

## 1.4 Declaration of Conformity.

**Manufacturer:** Bila A/S  
Industrivej 10  
7900 Nykøbing Mors  
DK-Danmark

Our type label to be inserted her

**Mashine type:** Palomat Greenline 153650 - 153651  
Palomat Greenline 156001 - 156101

**Used directive:** 2006/42/EF The Machine Directive

**Applied standards:** Refer to the next page

The Palomat is tested by the manufacturer and it is hereby declared that security and other equipment were satisfactory in the test.

### Note

This declaration solely covers the above type Palomat Greenline, and no form of connected equipment or functions.

**This declaration shall lapse immediately if changes to the equipment are made, or spare parts not recommended are used, without approval in writing by Bila A/S.**

**Date:** 01.11.2020

**Place:** Nykøbing Mors

**Signature:**



Jan B. Sørensen  
CEO

## 1.5 Applied standards

The list below covers the standards that fully or partially used during the development and construction of this Palomat according to the Machinery Directive.

### **Harmonised standards:**

DS/EN ISO 12100:2011 Safety of machinery – General principles for design – Risk assessment and risk reduction

## 2 Product Description:

### 2.1 Product Supply and Consumption Data

#### Dimensions

| Palomat Type: | Length           | Height              | Width              | Weight             |
|---------------|------------------|---------------------|--------------------|--------------------|
| 153650-12     | 1520mm<br>60 in. | 2350mm<br>92,5 in.  | 1556mm<br>61,3 in. | 405 kg<br>893 lbs  |
| 153651-12     | 1520mm<br>60 in. | 3750mm<br>147,6 in. | 1556mm<br>61,3 in. | 540 kg<br>1190 lbs |
| 156001-12     | 1520mm<br>60 in. | 2350mm<br>92,5 in.  | 1556mm<br>61,3 in. | 405 kg<br>893 lbs  |
| 156101-12     | 1520mm<br>60 in. | 3750mm<br>147,6 in. | 1556mm<br>61,3 in. | 540 kg<br>1190 lbs |

#### Lifting Power

| Palomat Type: | Number of lifting cylinders | Max. Lifting Power | Max. Number of pallets |
|---------------|-----------------------------|--------------------|------------------------|
| 153650-12     | 2                           | 500 kg<br>1102 lbs | 15                     |
| 153651-12     | 4                           | 700 kg<br>1540 lbs | 25                     |
| 156001-12     | 2                           | 500 kg<br>1102 lbs | 15                     |
| 156101-12     | 4                           | 700 kg<br>1540 lbs | 25                     |

#### Electric Data:

|                                 |  |
|---------------------------------|--|
| Power Input:                    | 100-240VAC / 50-60 Hz / 1P+N+PE  |
| Standby Consumption:            | 23 W   |
| Consumption during operation:   | 500 W (at max. load of 500kg/1102lbs)<br>700 W (at max. load of 700kg/1540lbs) |
| Noise Level:                    | 70 dB(A)   |
| Max. Fuse:                      | 16A  |
| Control module – 500kg/1102lbs: | EL/U31-H06-S33   |
| Software PLC - 500kg/1102lbs:   | U21-S33  |
| Control module – 700kg/1540lbs: | EL/U33-H06-S33   |
| Software PLC - 700kg/1540lbs:   | U21-S33  |

## 2.2 Keeping.

If the Palomat is not to be set up immediately upon receipt, buyer shall be responsible for checking, within a fortnight, that all parts have been included, informing the distributor about any deficiencies/shortages. After this, the Palomat is to be wrapped again as upon receipt, and to be left in dry, frost free surroundings.

## 2.3 Safety Information.

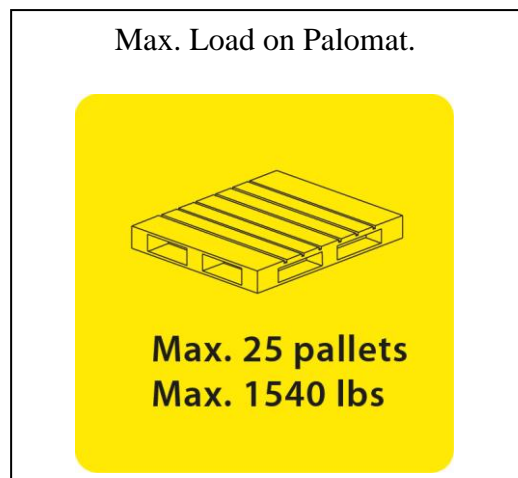
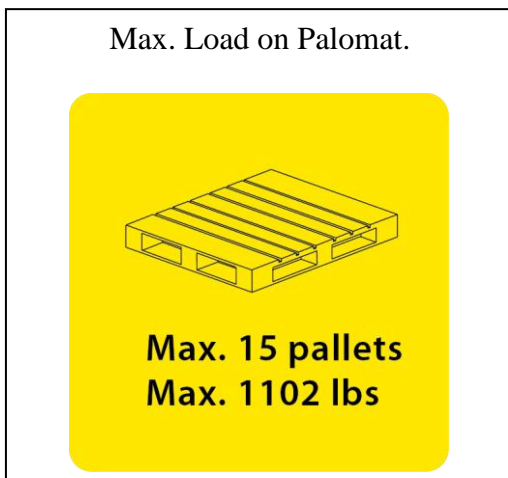

## Caution

This machine is intended for elevating and lowering pallets only. In case of using this machine for some other purpose, BILA A/S disclaims any responsibility/liability at all.

### **Specifically prohibited when using the machine:**

Staying inside the Palomat during operation is strictly prohibited.

The Palomat may not be used for lifting of persons.

### **Elimination of Risks:**

The Palomat is provided with shielding. The Palomat may not be operated if such shielding has been dismantled, or damaged so that some of the inside movable parts are made visible.

The Palomat has been equipped with an Emergency Stop, and may under no circumstances be blocked so that the operator cannot operate the Palomat.

### **Explosion Hazardous Environment**

Note that the Palomat is not ATEX approved for setting up in explosion hazardous environments.

## **3 Definitions:**

Definitions of terms used in this documentation.

### **List of Parts**

A list describing the particular parts of the machine.

### **Operating Staff**

Persons knowing the machine, and the risks connected with it. Not necessarily having any expert relevant knowledge of the mechanical and electrical items of the machine.

### **Maintenance Staff**

An expert person having a thorough knowledge of the particular field of work.

## 4 Preparation of product prior to use:

### 4.1 Transport.

Transport of the Palomat by truck or elevating truck may only be conducted from the front or from the back, using the transport pallet intended for that purpose.



Transport Pallet

### 4.2 Unwrapping.

The Palomat is placed on a transport pallet, and is wrapped in foil. These things are to be removed prior to use.



Plastic foil

### 4.3 Dismantling from transport pallet.

Remove the four bolts by which the Palomat is fastened to the transport pallet. (Fig1).



Fig.1

Then insert a pallet in the magazine using a truck (Fig. 2), and elevate the Palomat in the four grips free of the transport pallet.(Fig. 3)



Fig.2

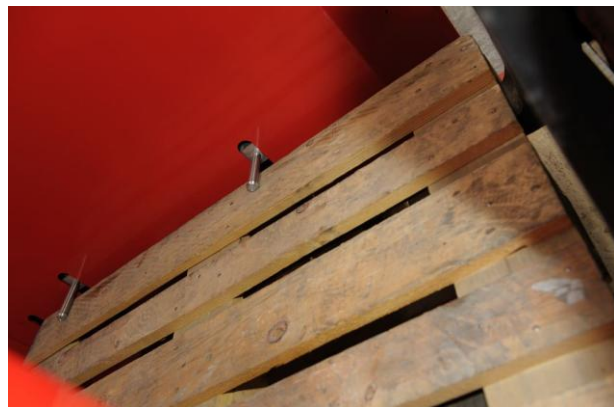

Fig.3

Now remove transport pallet, and place the Palomat at the place required. (Fig. 4)



Fig.4

#### 4.4 Setting Up.

Place the Palomat on a level base. The Palomat is not necessarily to be attached to the floor. This may, however, be recommended if the Palomat is fed by truck. Prior to any attachment to floor, the safety bottom plate is to be dismantled. (Fig. 1). Dismantle the bolts placed in the side shields. (Fig. 2).

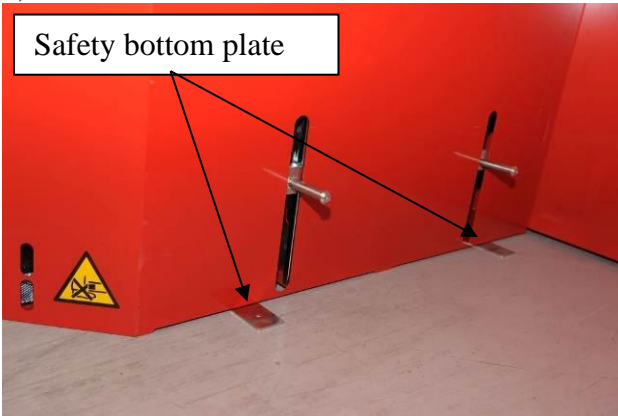

Fig. 1

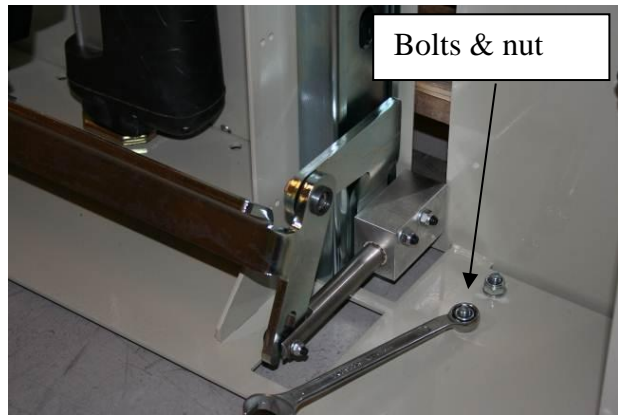

Fig. 2

After placing the Palomat, check the distance between the sides inside at the front and back. The distance is to be equal  $\pm 3\text{mm}$ . (Fig. 3)

Proceed by making sure all bolts and nuts are tight on the Palomat.

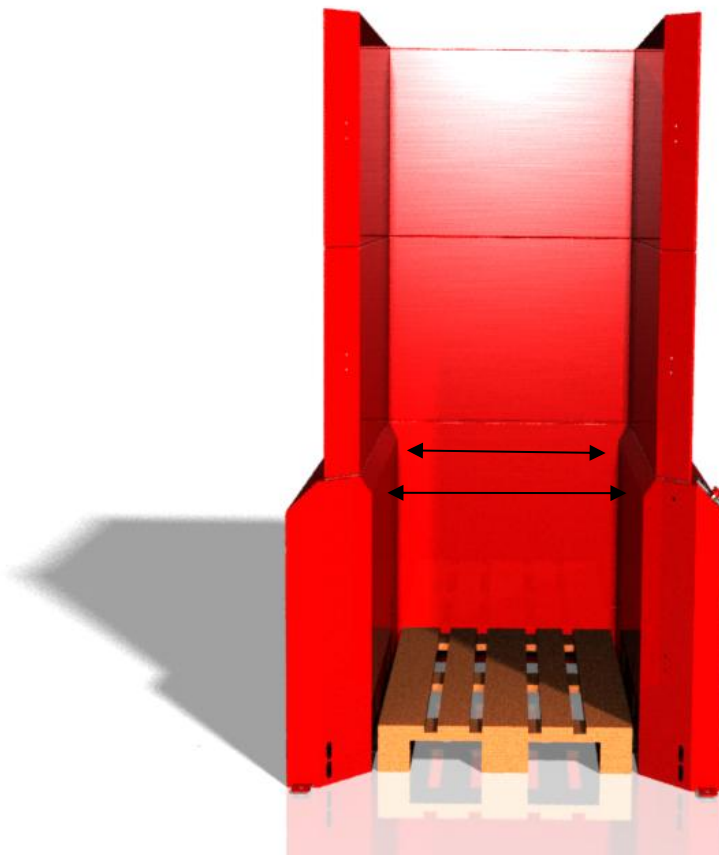

Fig.3

#### 4.5 Mounting in floor

The floor shall be made in min. 8 cm thick concrete which is level and firm for the Palomat to be bolted securely in it, using expansion bolts or adhesive anchors (M12).

Mark the holes for mounting in floor through the mounting holes placed in the front and on the back of the Palomat. Drill the holes, and secure the Palomat. Remember to mount spacing ring between floor and Palomat. (Fig. 4)



Fig4

#### 4.6 Safety Measures prior to use.

All sensors and functions **must** be tested before putting the PALOMAT into operation for the running of the daily work and all guards must be installed before use.

#### 4.7 Disposal of Wrapping

The wrapping consists of plastic foil and wood. Both may be disposed of as ordinary waste.

#### 4.8 Protection in periods without normal use.

If the Palomat is to be left unused for some considerable time, it is to be cleaned of dirt and liquid (water and oil). And then lubricated with a thin layer of oil for protection against unnecessary rust and corrosion. For cleaning, see section: Maintenance and Cleaning.

#### 4.9 Rewrapping.

Should moving the Palomat to a different location prove necessary, it will have to be rewrapped with foil and transport fittings. With a view to being able to transport the Palomat without running any risk of damage, neither to the machine nor to people. (vide section 2).

#### 4.10 Placing of guide.

This manual is to be available close to the Palomat. If this is not possible, the place where the manual is to be kept is to be clearly marked at the machine.

## 5 Operation.

The Palomat may be operated manually or automatically. Using the manual side of the panel will only be necessary for removal of entire pallet stack, or after alarm stop.

**!NOTE! Manual operation shall be subject to being run by instructed operators since the grips may be pulled back while the pallets are elevated in the stack.**

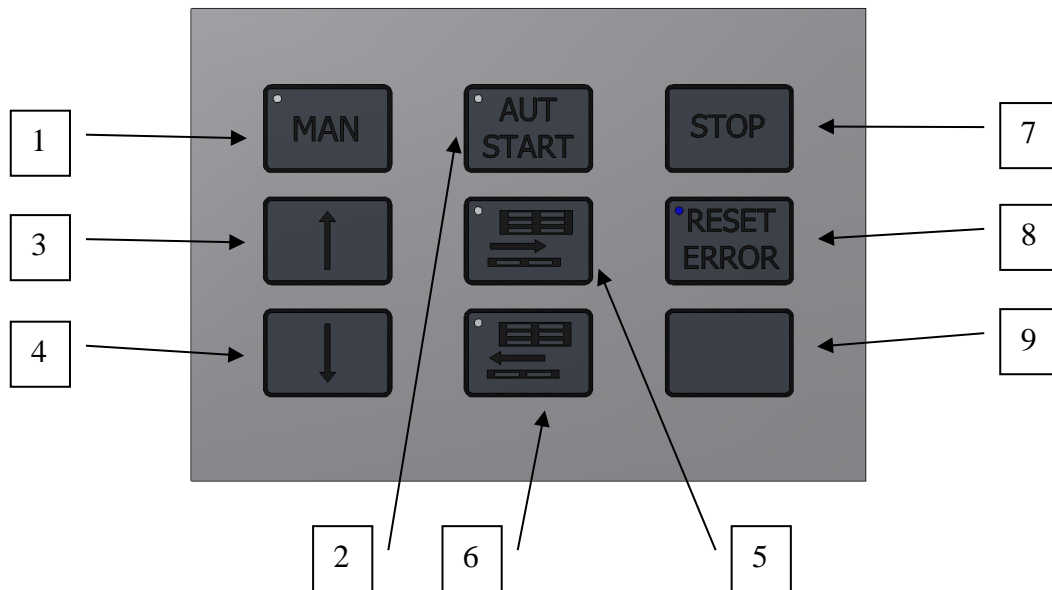

### 1. Manual.

Manual operation. Movements may be run up or down, and grip fingers out and in.

### 2. Auto/Start.

Start controls for stacking or de-stacking. Activated in two secs.

### 3. Arrow up.

Operation in MAN: Jack cylinder moving up.

### 4. Arrow down.

Operation in MAN: Jack cylinder moving down.

Operation in AUTO: Emptying function activated in five secs., and the Palomat will put the pallet stack on the floor.

### 5. Stacking/Grip in.

Operation in MAN: Removing grips from pallet.

Operation in AUTO: Controls for stacking of pallets.

### 6. De-stacking/Grip out.

Operation in MAN: Pushing grips into pallet.

Operation in AUTO: Controls for de-stacking of pallets.

**7. Stop.**

Stopping all movements and going into Manual

**8. Reset/Error.**

Reset: Acknowledgement for alarm. Keeping button depressed for two secs, and going into manual. At emergency stop, the energy is removed from the actuators.

Error: RESET/ERROR button flashing a number of times for error. Please check number of flashes under section 7.2

**9. Available.**

## **5.1 Stacking Function Description.**

1. The Palomat has been prepared according to item 4.3.
2. Check that "STACKING" button is on.
3. Push "AUTO/START" button for 2 secs.
4. The Palomat is now ready for use.
5. Run a pallet into the magazine, and remove the pallet elevator / truck upon which the pallet will be stacked.
6. Repeat item 5 until the max. number of pallets **or** weight has been reached.
7. When the max. number of pallets has been reached, depress "ARROW DOWN" button for five secs. After which the Palomat will put the stack on the floor. "STACKING" button flashing.
8. The pallet stack may now be removed.



## **5.2 De-stacking Function Description.**

1. The Palomat has been prepared to item 4.3.
2. Check that "DE-STACKING" and "AUTOSTART" buttons are on.
3. A pallet stack is run into the Palomat.
4. The Palomat will now elevate the stack, leaving the bottom pallet behind.
5. A pallet may now be removed, and will, after about 10 secs. from the pallet is gone, put a new pallet on the floor.
6. When the last pallet has been removed, repeat from item 3 again.

Switching between stacking and de-stacking in "Auto" mode may always be performed.

### 5.3 Function description for removal of pallet stack.

For emptying the Palomat of all pallets, press "Arrow Down" button  for five seconds after which the Palomat will put the stack on the floor. The stack may now be freely removed from the Palomat.

NOTE. The stacking  or de-stacking  button will flash when this function is active until the Palomat has been emptied of pallets.

### 5.4 Activation of Front Sensor

If the front sensor is broken while the Palomat is moving downward, the Palomat will stop and go into alarm. The "RESET/ERROR" button will then flash three times. To reset the alarm, push "RESET/ERROR" button for two secs., and the Palomat will go into manual. Then push AUTO/START for two secs. , and the Palomat will continue.

### 5.5 Activation of Emergency Stop / Hatch switch.

If the emergency stop/hatch switch is activated, the Palomat will stop all movements. The "RESET/ERROR" button will flash twice. Reset the alarm by releasing the emergency stop, and depress RESET/ERROR for two secs. The Palomat will now go into manual. Then push AUTO/START for two secs., and the Palomat will continue.

### 5.6 Description of the light tower (Option).

The light tower functions while operating the Palomat. The Palomat is mounted with a light tower with three colors, green, yellow, and blue, which is used to indicate whenever an operator can insert or extract pallets, when the Palomat is operating and when the Palomat needs action.

The green light indicates that the Palomat is ready for either receiving pallets or that pallets are withdrawn from it, hence the Palomat is ready to use.

The yellow light indicates that the Palomat is either stacking or de-stacking pallets, hence the machine is operating in one of its sequences.

The blue light is mounted in connection with a maximum/minimum indicator and will light up when the machine is full.

When the blue light flashes, it will show the same number of flashes equal to the error code.

## 6 Maintenance and Cleaning.

### 6.1 Safety Measures.

To eliminate any kind of risk of maintenance and cleaning, as well as service, the electric connection is to be switched off prior to maintenance. The electric connection is to be switched off at the building installation, or, whenever this is not possible, by disconnecting the Palomat at the plug.

## 6.2 Maintenance and Cleaning.

All tasks listed under this item shall be performed to the current safety rules, as mentioned in the item on Safety Measures above.

### Cleaning.

As the Palomat is equipped with various sensors and lines, cleaning may only be performed by using a weak basic detergent. Further, the Palomat may not be flushed but merely wiped over using a wrung cloth. This may be performed by the operating staff.

### Maintenance.

Maintenance shall be performed by expert staff.

## 6.3 Service Form.

It is important that the daily maintenance and service be performed in the manner optimal in view of the conditions. However, as a minimum, the following service form is to be adhered to. In case of lack of maintenance or actual non-performance, the Palomat warranty will lapse.

Note that the intervals below are estimates, and shall be revised by customer’s own maintenance department after the machine has been running for one year.

| Service Form  | Every month | Every six months | Each year |
|---|-------------|------------------|-----------|
| All sensors to be cleaned using a dry cloth.                                | X           |                  |           |
| Cleaning of entire Palomat  |             |                  | X         |
| C-Profiles to be greased with universal grease. (Possibly Blackbolt NSF H1) |             |                  | X         |
| Emergency stop, door switch (option) to be checked.                         |             | X                |           |
| Retightening bolts and nuts   |             |                  | X         |

## 7 Troubleshooting

In case of malfunction, **contact your dealer.**

| Fault/Error   | Explanation/Solution  |
|---|---|
| At stacking or de-stacking, the Palomat will stop until the cycle has been completed. | End pos. on actuator not reached. Or actuator is not running synchronously. / Set Palomat in "MAN", and release pallet. Pull back grips, and keep "RESET/ERROR" depressed for six secs. after which actuators will run to top. <b>You may contact your distributor.</b> |
| No light in panel.  | Check PLC fuse.<br>Fuse Size: 5x20mm 1 amp flink.   |



|  |  |
|--|--|
| <p>Palomat lifting actuator jerking, or running asynchronously</p>   | <p>Reset actuators in manual mode using Reset/Error button, to be kept depressed for six secs. after which actuators will return to top position.</p>  |
| <p>Palomat has been set for stacking. When a Palomat is inserted into the Palomat, it will not be stacked.</p> | <p>Bottom sensor in bag at right hand side is out of adjustment or faulty. Or pallet faulty, rearmost corner block may, for instance, be missing. <b>You may contact your distributor.</b></p> |

For troubleshooting, checking Palomat sensors may prove necessary.

**!Note! This check may be performed by expert staff only as the screening has to be dismantled during the check.**

### 7.1 Troubleshooting Procedure.

1. Empty Palomat of pallets.
2. Set Palomat for manual mode.
3. Move Palomat up/down and out/in using arrow keys, watching photocells.
4. In the form below, check mark whether photocells are illuminated.

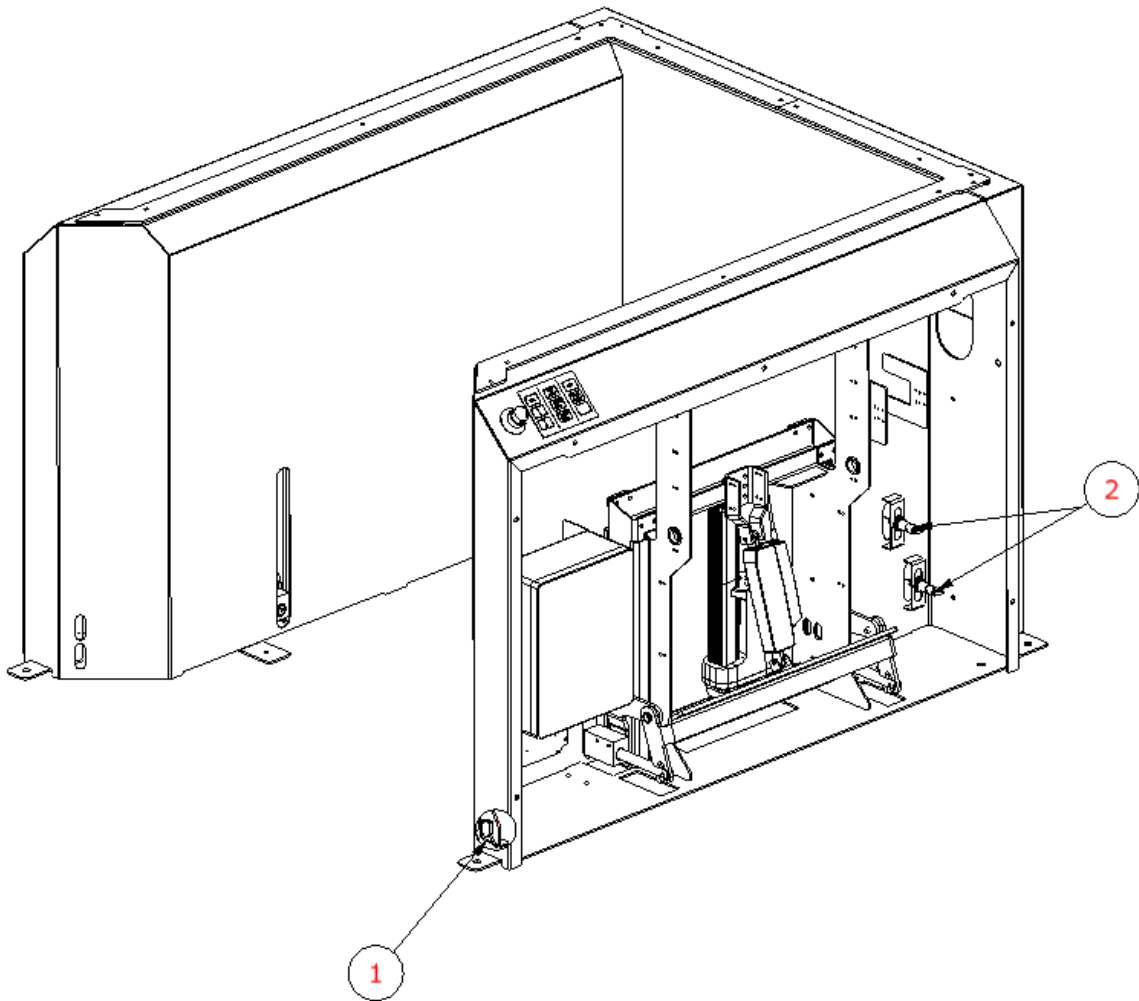

| Pos. No. | Designation   | No. | OK |
|----------|---|-----|----|
| 1        | Photocell in front "Emitting yellow & green light when light beam is not refracted" | 9B6 |    |
| 2        | Photocell in back "Emitting light when a pallet has been de-stacked in magazine"    | 9B7 |    |
| 2        | Photocell in back "Emitting light when a pallet is lifted up into the magazine"     | 9B5 |    |

## 7.2 Error Codes.

In case of error, the Reset/Error button will flash a number of times for alarm code

| Alarm code | Designation                      | Explanation / Solution  |
|------------|----------------------------------|---|
| 2          | Emergency stop/Door              | Emergency stop has been activated. Release emergency stop, and acknowledge for the error using the Reset/Error button. Or Door may have been open.  |
| 3          | Front sensor                     | Front sensor has been broken during operation. Acknowledging the error using the Reset/Error button.  |
| 4          | Grip error +                     | Grip actuator not reached its end pos. in + direction. Check that grip is not encountering resistance. Acknowledge error using the Reset/Error button.<br>Gripper will not move out or into (MAN) / Check fuse 4F7 (5AT). |
| 5          | Grip error -                     | Grip actuator not reached its end pos. back. Check that grip is not encountering resistance. Acknowledge error using the Reset/Error button.<br>Gripper will not move out or into (MAN) / Check fuse 4F7 (5AT).           |
| 6          | Lifting error +                  | Lifting Actuator not reached its end position in the top. Check the lifting actuators unopposed and error code on the EM-273 Parallel drive (See Appendix 11.1). Acknowledges the error with Reset / Error button.        |
| 7          | Lifting error -                  | Lifting Actuator not reached its end position in the bottom. Check the lifting actuators unopposed and error code on the EM-273 Parallel drive (See Appendix 11.1). Acknowledges the error with Reset / Error button.     |
| 8          | Lifting error middle from bottom | Lifting actuator not reached its middle position from the bottom. Please check the reed switch (10B1) on the actuator (-7M1) is defective. Acknowledges the error with Reset / Error button or contact your dealer.       |
| 9          | Lifting error middle from top    | Lifting actuator not reached its middle position from the top. Please check the reed switch (10B2) actuator (-7M1) is defective. Acknowledges the error with Reset / Error button or contact your dealer.                 |

## 7.3 Troubleshooting actuators.

Is the actuator running in manual mode? If there is an actuator that is not moving at all, one must assume that the DC motor or the power supply is faulty.

If nothing is moving, the power supply fuse must be checked.

If one of the actuators is moving incrementally while the second actuator is stationary, **the actuator that is moving incrementally is the faulty one.** The actuator that is stationary will move one step each time the direction is changed, but otherwise not move. **The actuator that is standing still is OK!**

The actuator that is moving incrementally has steering problems. This may be caused by missing pulses, errors in the power supply or poor connections in the connector / terminal. If the actuator on

the right (PLC and panel) side is defective, this can be identified if the pulses to the PLC inputs 0.0 and 0.1 are correct. These inputs will blink when the actuator is running. If the actuator on the other side is defective, this cannot immediately be seen because these pulses go directly to the Linak steering synchronisation PCB.

If the actuators are in a position that makes it impossible to run them manually, you can attempt Homing by holding the Error Reset button down for 5-6 seconds. Then you should be able to run manually again.

If you choose to replace an actuator, it is important to drive the defective actuator completely down in manual mode so that it is in the same position as the new actuator. This makes it easier to Home in the first attempt. If you fail to Home the new actuator in the first attempt, you can run it manually a bit and then try to Home it again.

## 7.4 Trouble shooting step by step on PLC

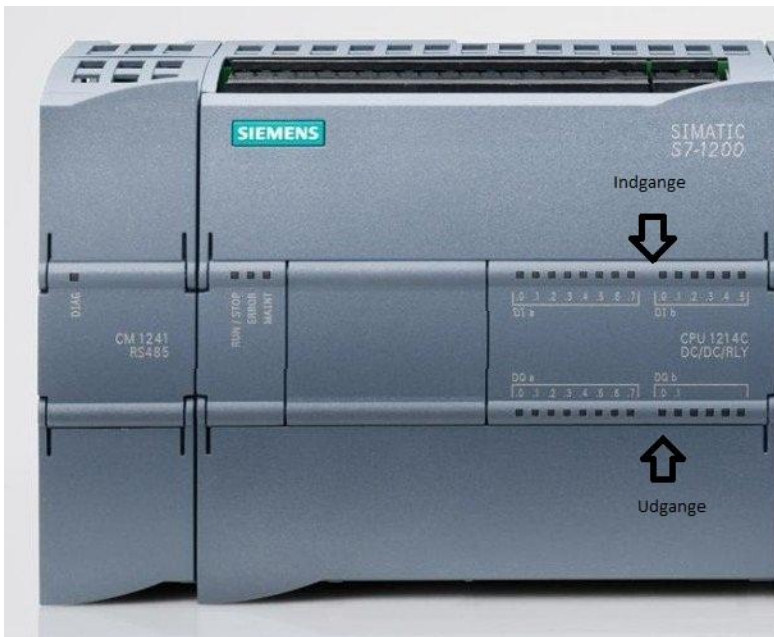

- **Step by step overview for stacking sequence on PALOMAT Greenline**

1. Lifting motor is down and gripping motor is retracted, signal [7M1(DI0.3) lifting motor -] and signal [8M1,8M5 (DI2.1 + 8K4) gripping motor -] is activated and the PALOMAT waits for a pallet.
2. A pallet goes in.
3. When the sensor at the back [9B7 (DI0.7) pallet down innermost] is activated and front sensor [9B6 (DI0.6) Floor free front] is clear, the gripping motor moves in and signal [8M1,8M5 (DI0.4 + 8K3) gripping motor +] is activated.
4. Lifting motor moves in to signal [7M1 (DI0.2) lifting motor +] is activated.
5. The PALOMAT waits for a new pallet.
6. A pallet is run in.
7. When [9B7 (DI0.7) pallet down inside] is activated and front sensor [9B6(DI0.6) Floor free front] is clear, the lifting motor runs down to the middle position and the gripping motor retracts, and signal [8M1,8M5 (DI2.1 + 8K4) gripping motor -] gripping motor -] is activated.
8. Lifting motor runs to the bottom, and signal [7M1(DI0.3) lifting motor -] is activated.



9. Gripping motor moves in and signal [8M1,8M5 (DI0.4 + 8K3) gripping motor +] is activated.
10. Lifting motor moves in to signal [7M1 (DI0.2) lifting motor +] is activated.
11. PALOMAT continues from point 5 again.

- **Step by step overview for destacking sequence on PALOMAT Greenline**

1. Lifting motor stands in middle position and gripping motor is retracted, and signal [8M1,8M5 (DI2.1 + 8K4) gripping motor -] is activated and the PALOMAT waits for a pallet.
2. Pallet stack is run in.
3. When the sensor at the back [9B7 (DI0.7) pallet down innermost] is activated and front sensor [9B6 (DI0.6) Floor free front] is clear, the gripping motor moves in and signal [8M1,8M5 (DI0.4 + 8K3) gripping motor +] is activated.
4. Lifting motor moves up to signal [7M1 (DI0.2) lifting motor +] is activated and a pallet is ready on the floor.
5. A pallet is picked up.
6. When front sensor [9B6 (DI0.6) Floor free front] is clear and sensor at the back [9B7 (DI0.7) pallet down innermost] is not activated, the lifting motor runs to the bottom and signal [7M1(DI0.3) lifting motor -] is activated.
7. Gripping motor moves back, and signal [8M1,8M5 (DI2.1 + 8K4) gripping motor -] gripping motor -] is activated.
8. Lifting motor runs up to middle position and gripping motor moves forward, signal [8M1,8M5 (DI0.4 + 8K3) gripping motor +] is activated.
9. Lifting motor runs to the top, and signal [7M1 (DI0.2) lifting motor +] is activated.
10. PALOMAT continues from point 5 again until the PALOMAT is empty.

## 8 List of Spare Parts and Consumables.

For any replacement of spare parts in the Palomat, parts identical with those of the list are to be used. Please contact your dealer if so required.

Note: Replacing with parts not identical with those recommended in this manual shall cause manufacturer’s liability to lapse.

**!NOTE! Power must be disconnected and locked before replacing.**

### 8.1 Spare Parts Drawing

| Pos. | Designation   | Bila No.       |
|------|---|----------------|
| 1    | PLC control complete – 500kg/1102Ibs                  | EL/U31-H06-S33 |
| 1    | PLC control complete – 700kg/1540Ibs                  | EL/U33-H06-S33 |
| 2    | Photo Sensor - SICK FOTO-REFLEX GL6-P1212             | EL/1060815     |
| 3    | Grip guide house                                      | 180006_V2      |
| 4    | Grip shaft  | 183025-M_V2    |
| 5    | C-Profile guidance (complete per side)                | 180007_V1      |
| 6    | Jack Actuator - 365B03+2H250B20                       | 57920240-M     |
| 7    | Grip Actuator - 120443-00 (RIGHT)                     | 57920246       |
| 7    | Grip Actuator - 1200-0000-0240-DK (LEFT)              | 57920247       |
| 8    | SICK DIFFUSE PHOTOELECTRIC SENSOR GRTE18-P1237        | EL/1121486     |
| 9    | Control Panel   | EL/2474S003    |
| 10   | Emergency stop push - SICK PUSHBUTTON ES21-AT112      | EL/5321157     |
| 12   | Hatch switch – SICK i10-PA213 (Option 153650-XX)      | EL/6025088     |
| 13   | Max indicator – SICK FOF DIFFUS VTE18-3F4740 (Option) | EL/6013332     |

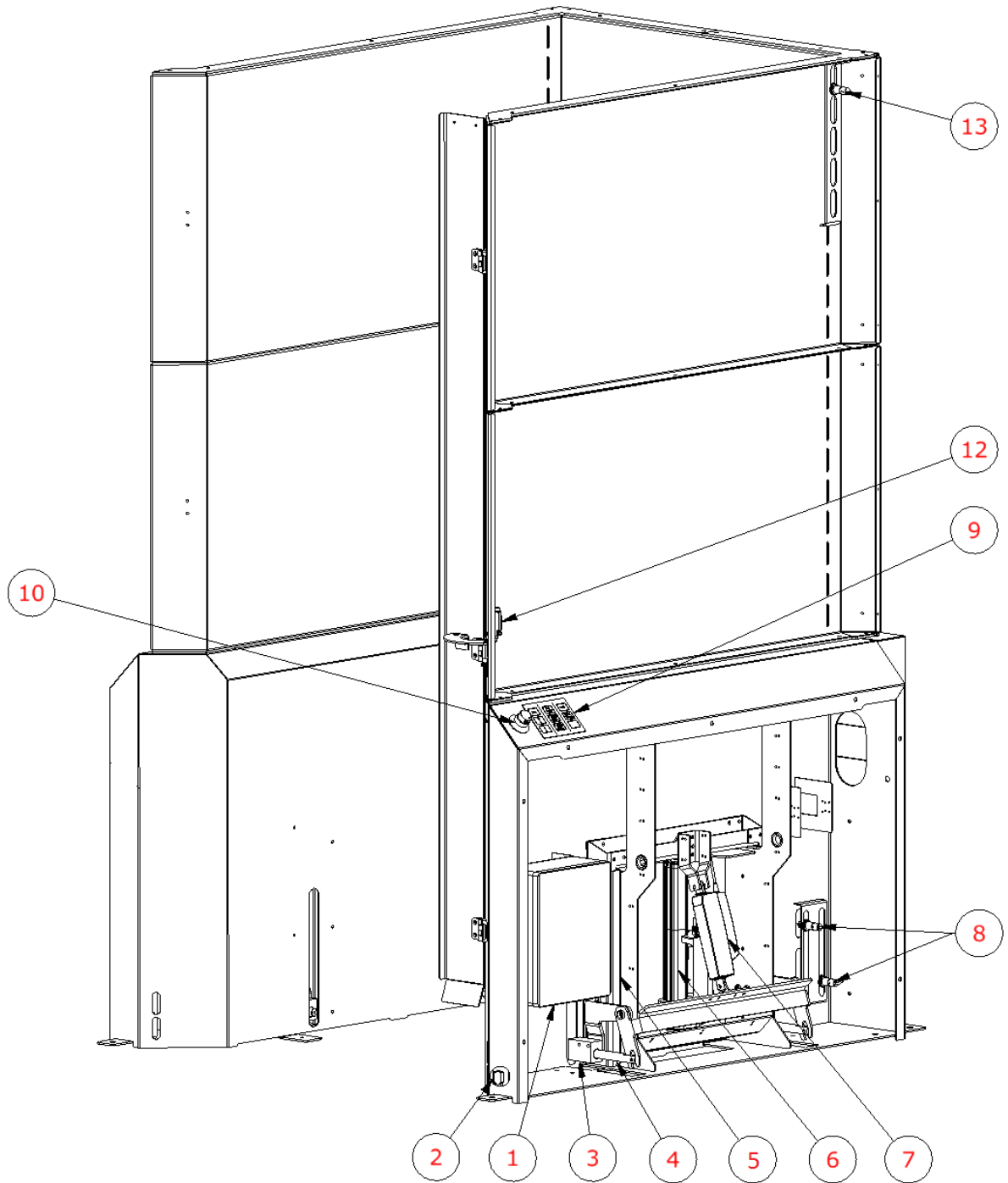

## 8.2 Wiring Diagram

See data sheet example.



## **9 Taking product out of service.**

When the Palomat is to be scrapped, taking it apart will be appropriate, doing so in its most recent place – thus avoiding any need to mount transport fittings again to enable secure moving, at no risk to people.

Once the Palomat has been taken apart completely, an expert may sort out the various materials from each other, for all of these to be sent for reuse.

No chemicals or materials hazardous to health form part of the Palomat.

### **9.1 Own Notes:**

## 10 Options.

### 10.1 Assembly Guide for subsequent assembly of 15-pallet safety frame.

For mounting of safety frame on the Palomat, the directions below must be observed.

**!NOTE! Power must be disconnected before dismantling the side shielding.**

1. Remove top bolts (1) on top of Palomat, as shown in Fig. 10.
2. Place back shield (2) inside level with Palomat inside.
3. Place sides (3), track facing rear shield (2), and attach to rear shield.
4. Fasten shields using the 8 mm bolts and nut provided.
5. Repeat from item 2 for assembly of next section.
6. Finish by placing fish plate (4) at the top of the safety frame, and tighten bolts.

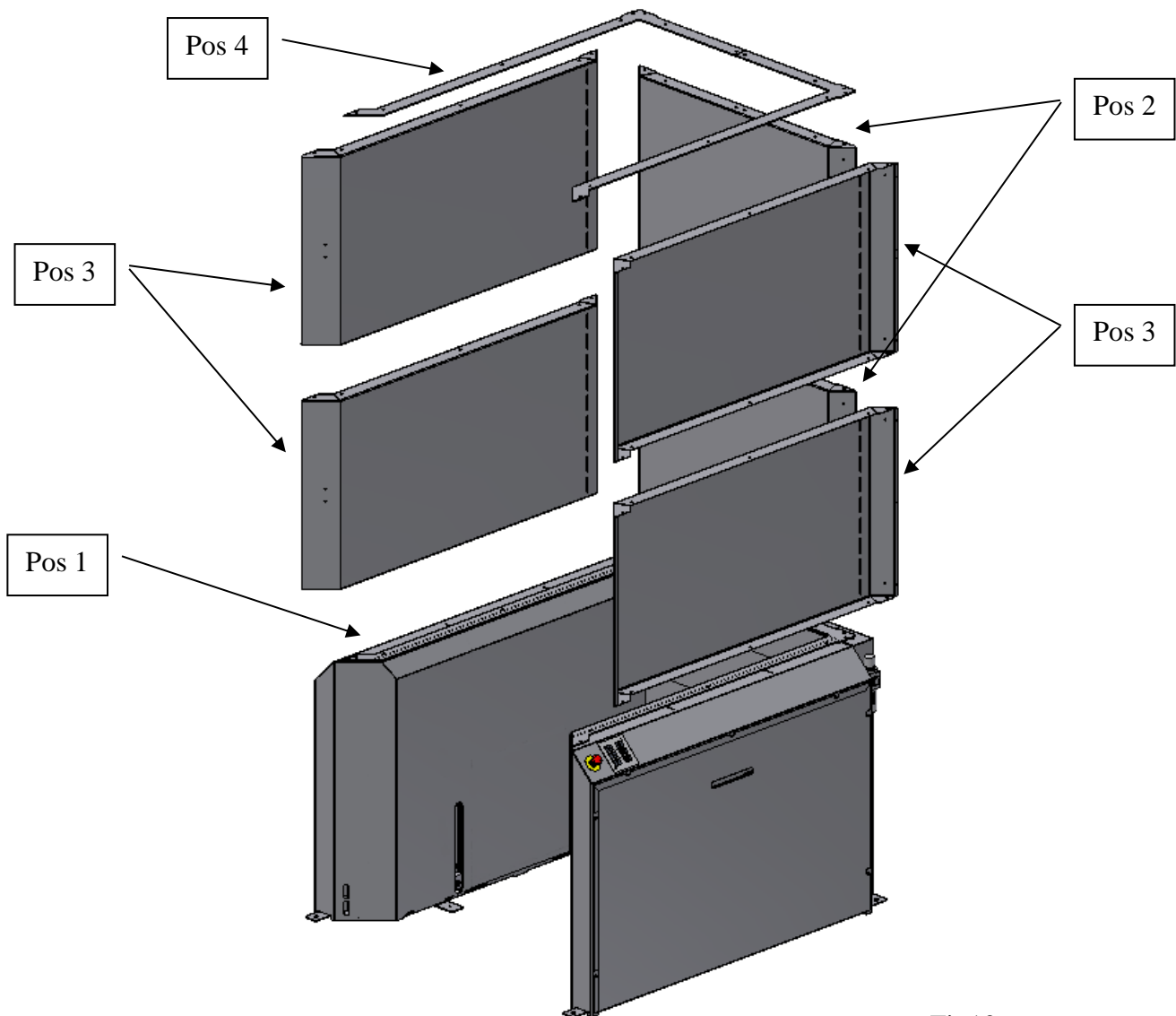

Fig10

## 10.2 Assembly Guide for subsequent assembly of 25-pallet safety frame.

For assembly of safety frame on the Palomat, the directions below must be observed.

**!NOTE3! The power must be disconnected before dismantling the side shielding.**

1. Remove top bolts (1) on top of Palomat, as shown in Fig. 11
2. Place back shield (2) inside level with Palomat inside.
3. Place sides (3), track facing rear shield (2), and attach to rear shield.
4. Fasten shields using the 8 mm bolts and nut provided.
5. Repeat from item 2 for assembly of next section.
6. Then mount front door (4) with bolts provided
7. Finish by placing fish plate (5) at the top of the safety frame, and tighten bolts.

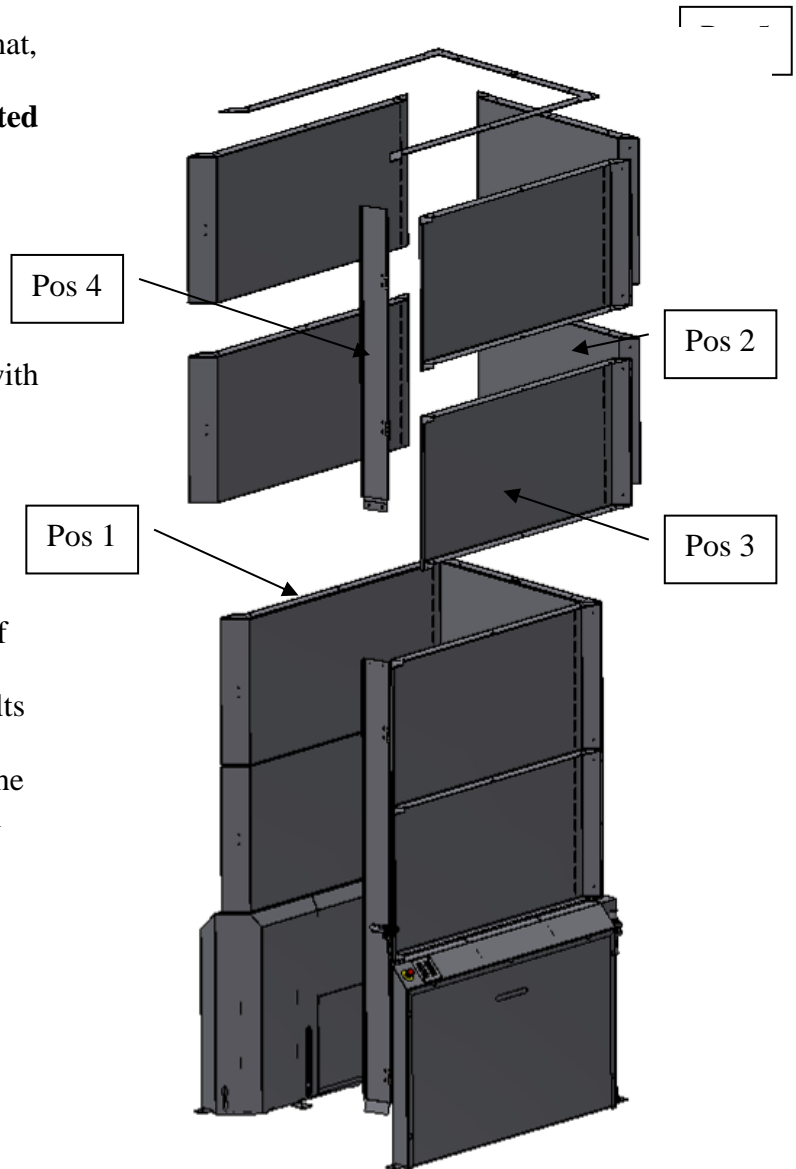

Fig. 11

### 10.3 Installation instructions for 25 pallets Max indicator (Option).

For installation of Max indicator on Palomat, the following instructions must be observed.

**NOTE! Electricity must be disconnected before the side panels are dismantled.**

1. Fit the Max indicator consol on the superstructure at the rear on the right side.
2. Fit the Max indicator on the bracket about 20 mm above the height of a stack of 24 pallets lifted into the magazine.
3. Place the cable into the edge of the superstructure as shown in Figure 11 and then pop it through the hole in the side panel (Figure 12) and into the side panel to be fastened in the electrical cabinet.
4. Secure the cable in the superstructure using cable ties as shown in Figure 12.
5. Fit the cable in the electrical cabinet according to the wiring diagram supplied.



Fig. 11



Fig. 12

### 10.4 Adjustment of the Max indicator

When adjusting the Maxi indicator for e.g. 25 pallets, 24 stacked pallets are placed in the magazine. Then place the Max indicator about 20 mm above pallet no. 24 to ensure that only 25 pallets can be stacked.

When the Palomat tries to stack pallet no. 25, it will receive a signal from the Max indicator and then put the stack of 25 pallets down and retract the grippers so that the stack can be removed.

## 11 Appendix

### 11.1 Linak management TR-EM-239 Parallel Drive

Instruction Manual for TECH-system type 239



#### Troubleshooting

If an error occurs, the actuators will stop operating and the error condition will be indicated by a red LED on the PCB. The LEDs are visible when the cover of the control unit is removed.

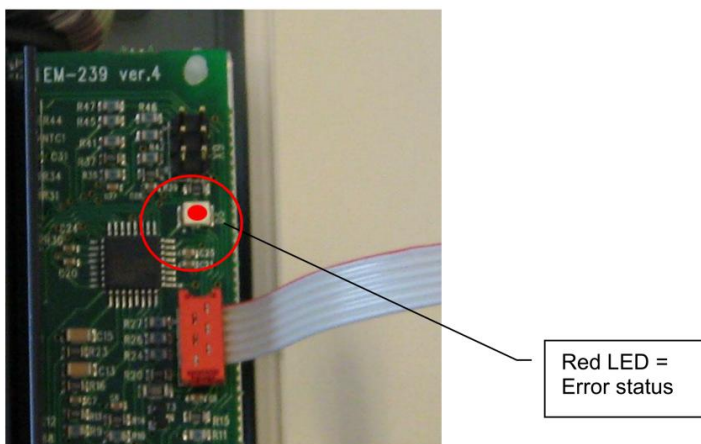

#### Reading errors

In the event of an error, the red LED will flash. The flashes have the following meaning:

| Number of flashes | Meaning                                 | Check this   |
|-------------------|---|--|
| 2 flashes         | Disconnected on account of over current | - Too heavy load. Release some loads from the Actuators<br>- Check that the value parameter 5 is correct |
| 3 flashes         | No pulses                               | - Check the cabling and connections at Terminal 7 and 8<br>- Replace Actuator                            |
| 4 flashes         | Deviation in pulses                     | - Initialise the system  |
| 5 flashes         | Overheating                             | - Stop system and wait until it is cooled down   |

#### Resetting errors

All errors are reset when the actuators are restarted.